

# CASE STUDY

## 24/7 REMOTE PLANT CONTROL



REMOTE ACCESS FOR YOUR CONTROL SYSTEM NETWORK



*“The MET Connect™ remote access platform allows us to get instant remote support from our Engineering team as well as run our plant operations remotely. This has greatly reduced our down-time and ongoing operational costs.” - Michael Short, CQ Flyash Manager, Cement Australia*

### Customer

Cement Australia  
Pozzolanic Group

### Location

Callide Power Station, Biloela,  
Queensland

### Challenges

- > Remote Location
- > High Uptime Requirement
- > Large Ctrl system network  
(high data volume)

### MET Connect™

#### Products & Services

- > Remote Access
- > Remote Monitoring
- > 25GB / Month Plans
- > MET Connect™ *Blue Box*
- > Redlion 4G LTE MODEM

### Results

- > 24/7 Remote Control
- > Unmanned Plant Operation
- > Greatly reduced support costs
- > Increased Network Security

### Project Scope

Cement Australia, who run the ash plant at Callide Coal Power Station, had three specific needs:

1. An access system to allow the engineering team located 600km away to make PLC and HMI changes on an ongoing basis.
2. 24/7 Remote monitoring of an HMI for a third-party. This necessitated a heavily locked-down firewall to prohibit access to the rest of their control system network.
3. Remote control of their plant to allow unmanned operation on weekend shifts.

### Solution

Cement Australia deployed the MET Connect™ Remote access and monitoring platform to meet their three specific objectives.

Because of the 24/7 Nature of the sites operation, two separate remote access accounts both hosted in different data centres and running on different 3G MODEMS were provisioned and installed. In the event that one system was not available the operator would simply switch to the other remote connection.

## On-Site Benefits

Plant operators now take their iPad with them when visually inspecting the plant and troubleshooting issues with valves. No requirement for another operator standing-by via radio in the control room. They can securely view and control the Allen Bradley Panelview HMI from their iPad in the field. No additional VPN software needs to be installed. The in-built iOS VPN Client and a VNC Viewer is all that's required.

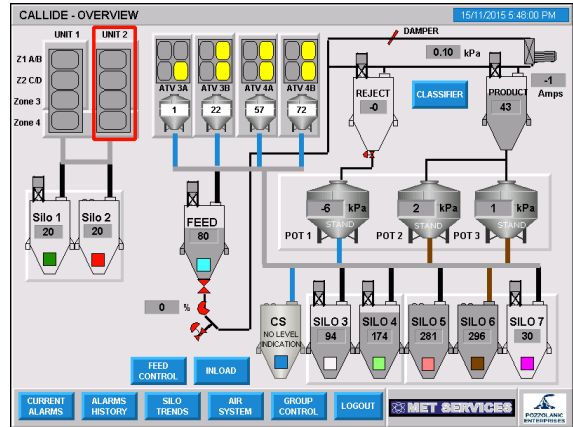

- 

Manage Users

Add, delete or edit user accounts.
- 

Manage Groups

Add, delete or edit groups.
- 

Manage Access Lists

## Security Benefits

Administrative Control over network access is managed by the plant manager. They use the MET Connect™ Manager software to add new accounts when they hire staff. They also can remove old accounts when staff leave the organisation. This allows the manager to keep a firm control over this important secure network.

## Monitoring Benefits - Web Based Visual Insight

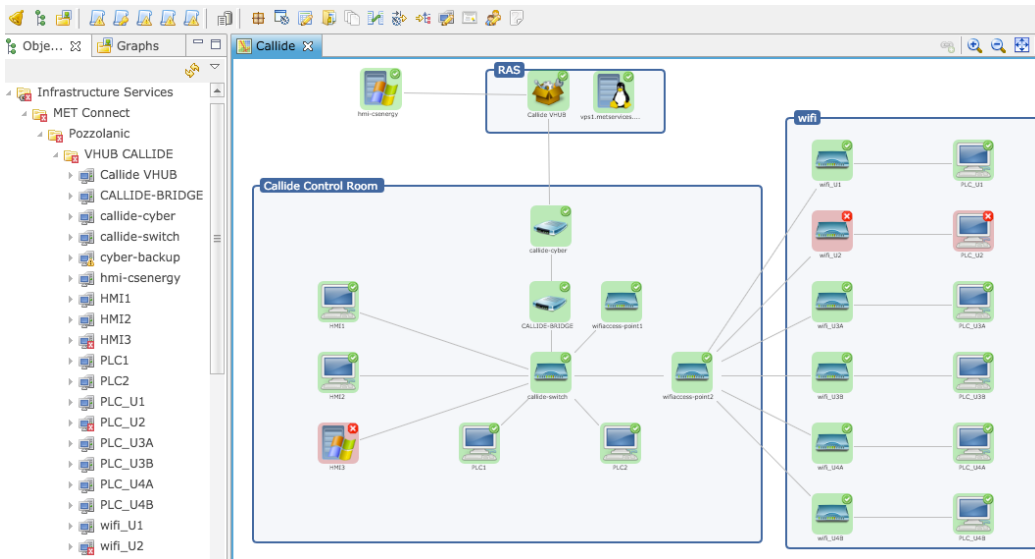

The MET Connect™ Web-based Monitoring Platform continuously checks the HMI servers to ensure the applications are functioning correctly. If the HMI service shuts down or the node is unavailable, Support Engineers are alerted immediately and can respond. The Network Operations Centre has full visibility of this control system network as well as other networks which they monitor.

Contact our team on +61 (0)7 3390 81 55 to discuss your remote network access needs.

